

Einbauanleitung Heizung *Installation Instruction Heating Resistor*



**für Einbau in Antriebe der Baureihen PSL, PSQ und PSR
*for installation in PSL, PSQ and PSR actuator series***

Inhaltsverzeichnis / Table of contents

1. Einbau Heizung / *Insert Heating Resistor*
2. Einbau Klemmleiste / *Insert Terminal*
3. Klemmen-Übersicht / *Terminal overview*



Vorsicht! Lebensgefährliche elektrische Spannung kann anliegen! Sach- oder Personenschäden sind durch geeignete Maßnahmen und Einhaltung der Sicherheitsstandards zu vermeiden!

Caution! Dangerous electrical voltage can be present! Avoid personal or material damages by observing applicable regulations and safety standards!

1. Einbau Heizung / Insert Heating Resistor

PSL201-210

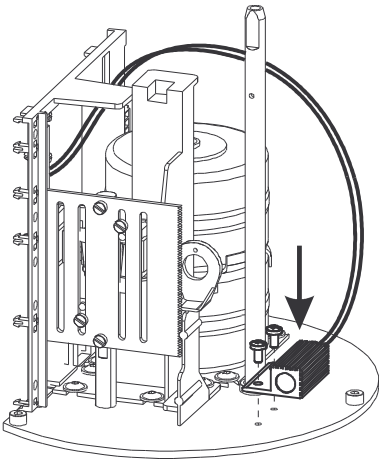

PSL305-314

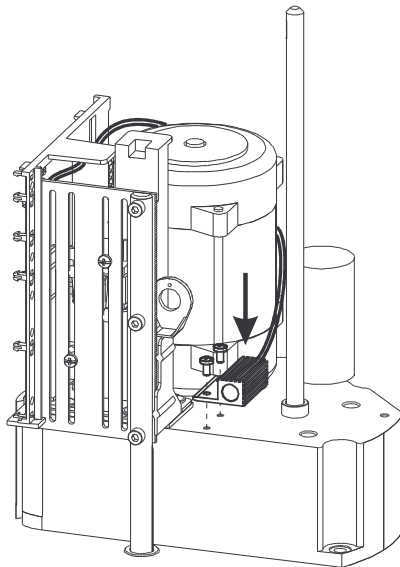

PSL320-325

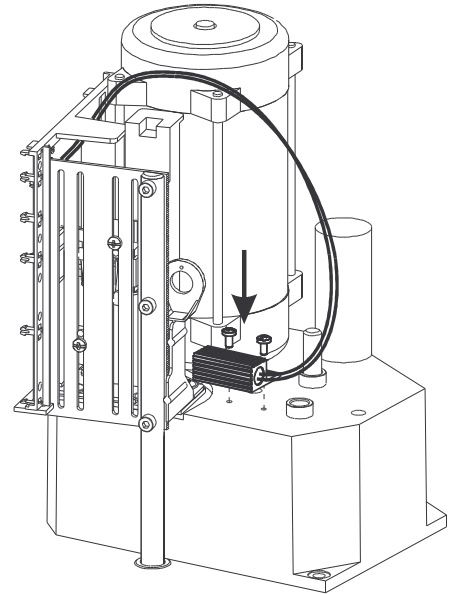

PSQ

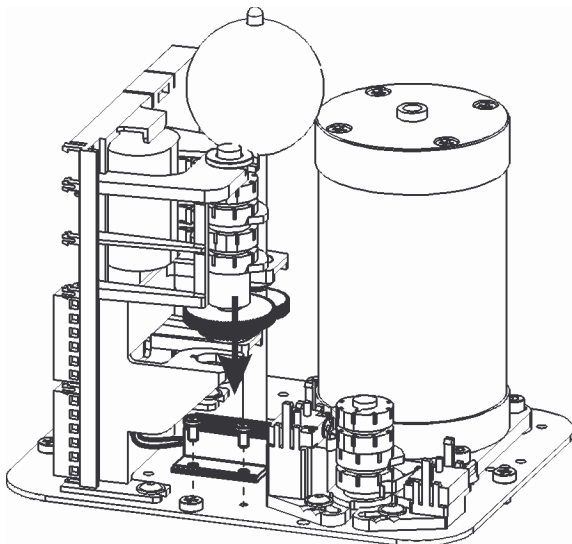

PSR

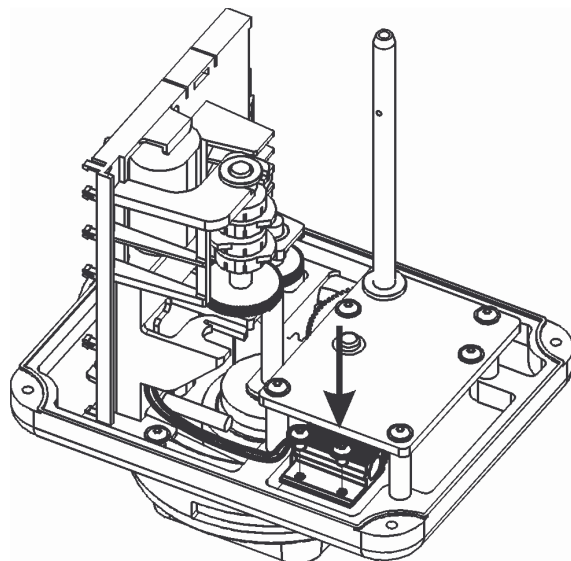

2. Einbau Klemmleiste / *Insert Terminal*

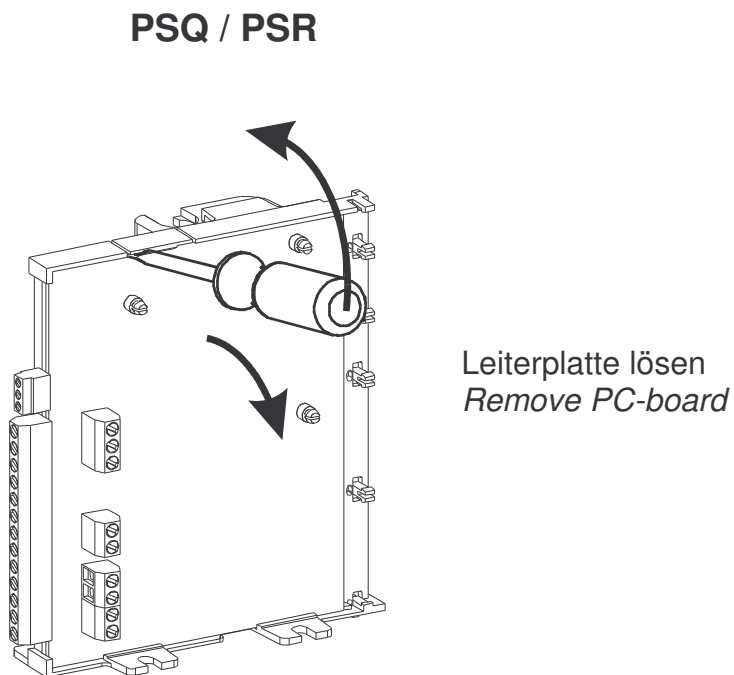
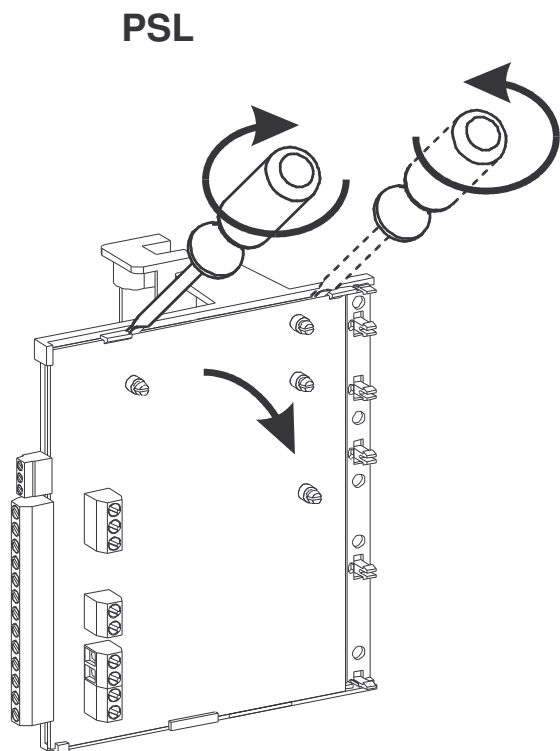

Klemmleiste X8 einsetzen / *Insert terminal X8*

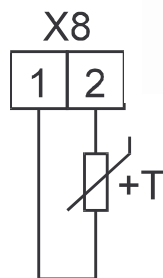
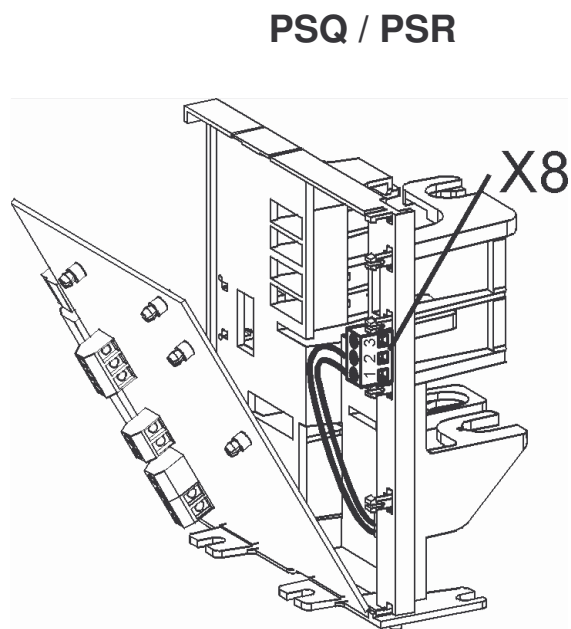
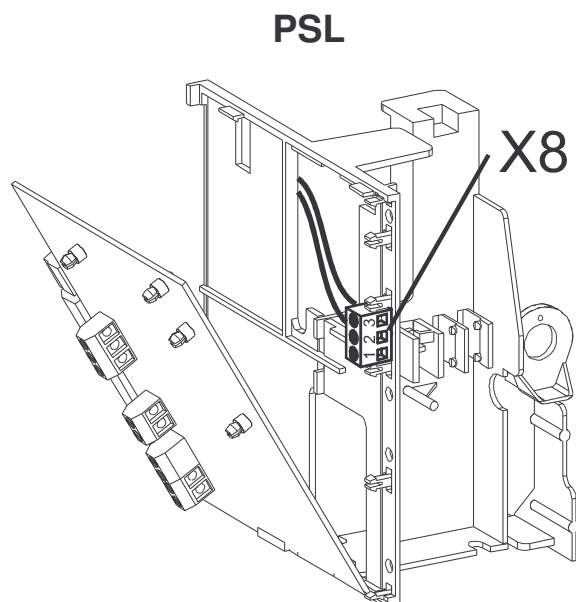

3. Klemmen-Übersicht / *Terminal overview*

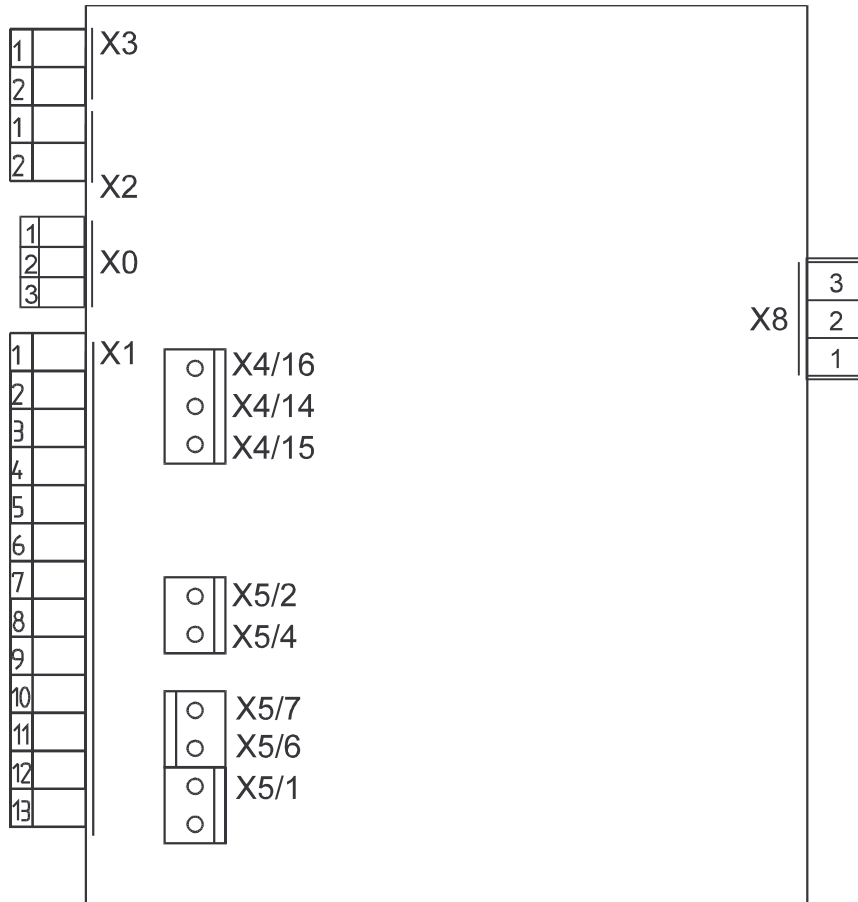

PS Automation GmbH
Gesellschaft für Antriebstechnik
Philipp-Krämer-Ring 13

D-67098 Bad Dürkheim

Tel.: <+49> (0) 6322 – 60 03-0
Fax: <+49> (0) 6322 – 60 03-20

e-mail: info@ps-automation.com
Internet: www.ps-automation.com